

Ground Floor

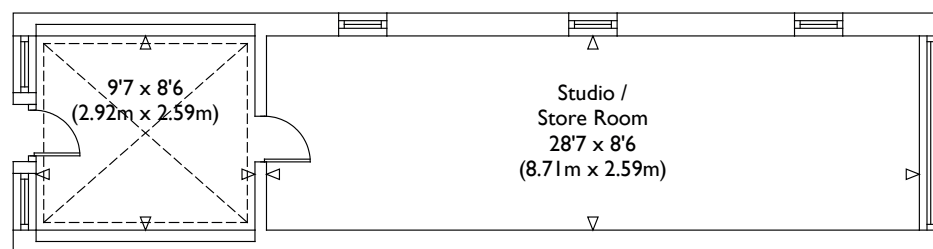

Outbuilding Ground Floor

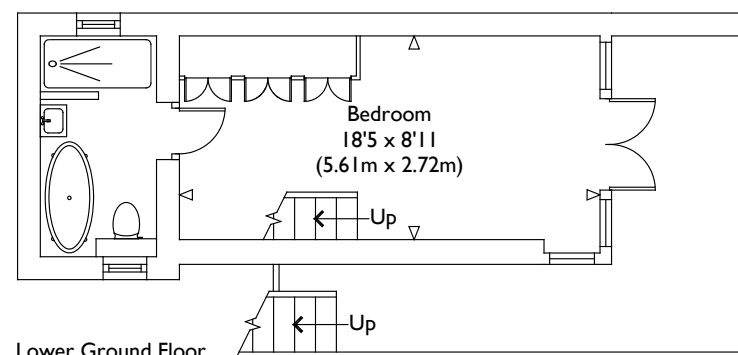

Lower Ground Floor

Illustration for identification purposes only, measurements are approximate, not to scale.

VIEWING ARRANGEMENTS
Telephone: +44 (0)20 3795 5920
Email: viewings@themodernhouse.com

HAWKHURST, KENT TN18

Approximate Gross Internal Floor Area : 2181 sq / 202.6 sq m (excluding Outbuilding)
Approximate Gross Internal Floor Area : 2510 sq / 233.2 sq m (including Outbuilding)

THE MODERN HOUSE