

Ground Floor

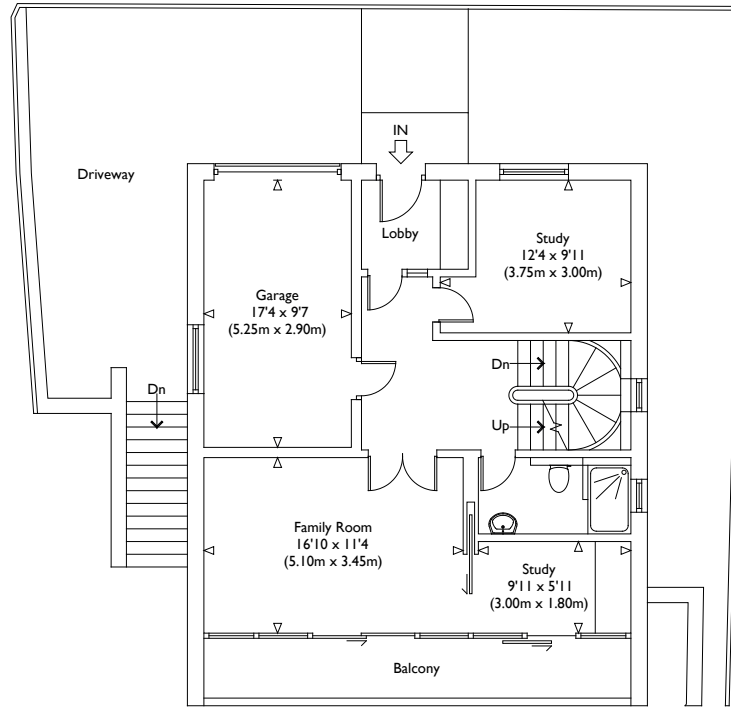

First Floor

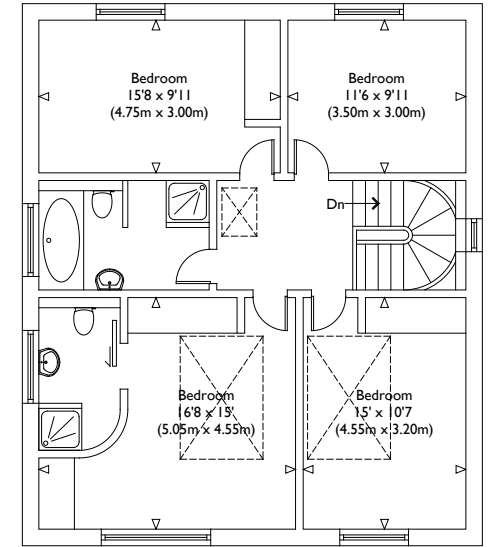

Second Floor

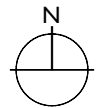

Illustration for identification purposes only, measurements are approximate, not to scale.

VIEWING ARRANGEMENTS
 Telephone: +44 (0)20 3795 5920
 Email: viewings@themodernhouse.com

PRINCE EDWARDS ROAD, LEWES, EAST SUSSEX BN7

Approximate Gross Internal Floor Area : 2326 sq ft / 216.1 sq m

THE MODERN HOUSE