

Ground Floor

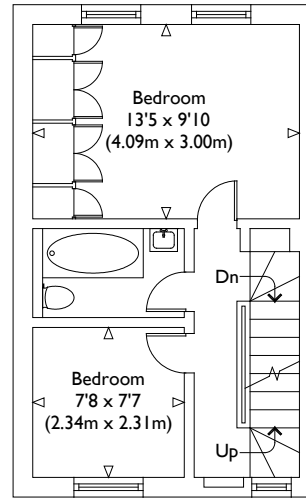

First Floor

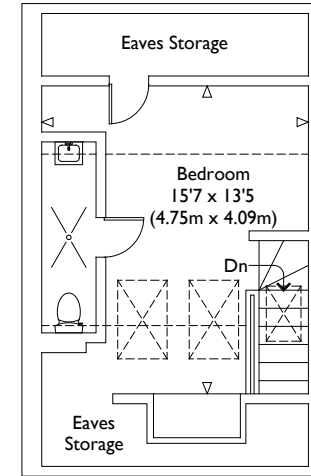

Second Floor



Illustration for identification purposes only, measurements are approximate, not to scale.

VIEWING ARRANGEMENTS  
Telephone: +44 (0)20 3795 5920  
Email: [viewings@themodernhouse.com](mailto:viewings@themodernhouse.com)

MARNE STREET, LONDON, W10

Approximate Gross Internal Floor Area : 1075 sq ft / 99.9 sq m  
(Including Restricted Height Area / Eaves Storage)

THE MODERN HOUSE